

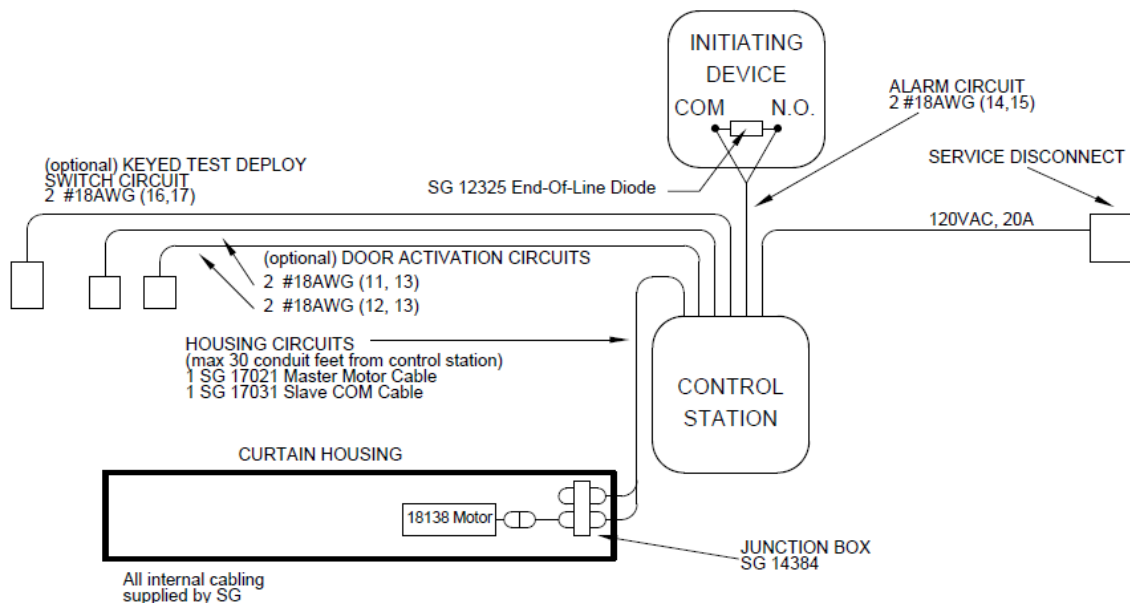

# Model 4000 Electrician's Guide

## Single Motor System

1. Install END-OF-LINE DIODE (furnished by Smoke Guard) at the INITIATING DEVICE.
2. Provide ALARM CIRCUIT from INITIATING DEVICE to CONTROL STATION.
3. Provide SERVICE DISCONNECT SWITCH and 120VAC to CONTROL STATION. (10A max)
4. Provide HOUSING CIRCUITS from CONTROL STATION to HOUSING using cables from the HOUSING JUNCTION BOX, furnished by Smoke Guard.
5. Provide optional KEYED TEST DEPLOY SWITCH, and DOOR ACTIVATION SWITCH circuits as required.



This product is intended to be installed in accordance with the National Electric Code NFPA 70, National Alarm Code NFPA 72 and within the limits of the authority having jurisdiction.

# Electrical Contractor Main Responsibilities

## ***Alarm circuit***

---

- Provide a conduit as required to connect two 18 or 20AWG stranded wires between the control station low voltage compartment and the initiating device. Label the wires 14 and 15.
- At the building alarm device, connect the wires between the normally open contacts in parallel with Smoke Guard EOL-Diode, P/N 12325. Order of wires does not matter.

## ***120 VAC***

---

- Install main power wiring through a ½" conduit into the control station high voltage compartment. Connect L, N and GND to terminal block.
- Provide service disconnect switch near control station.

## ***Housing circuits***

---

- Provide 1" conduit between the master control station and the main junction box at side of housing.
- At the control station (18246/18277), use the 1" knockout at the low voltage compartment. Flexible conduit at the housing will ease installation.
- At housing junction box pull free end of Cable 17021 and Cable 17031 to control station.  
SG Cable 17021 30' Master Motor Cable consists of:
  - two 14 AWG stranded wires, labeled 1 and 2.
  - five 22 AWG stranded wires, labeled 3 through 9.

## ***Optional keyed test deploy switch circuit***

---

- Provide junction box and conduit between the keyed test deploy switch and the control station.
- Provide two 18 or 20 AWG stranded wires labeled 16 and 17.

## ***Optional door activation switch circuit(s)***

---

- Provide junction box and conduit between the door activation switch(es) and the control station.
- Provide two 18 or 20 AWG stranded wires for each switch
  - first switch: labeled 11
  - second switch: labeled 12
  - ground wire: labeled 13

# Control Station (18246/18277 Configurations)

Verify that the configuration switches SW1 are set as illustrated:

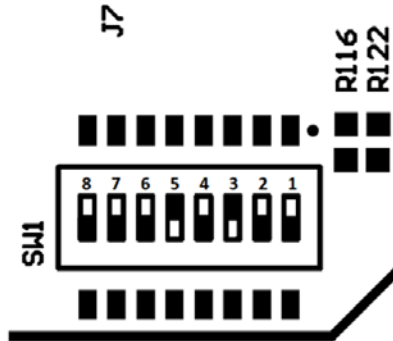

Verify that the current limit trip jumper J18 is set for 25A power supply as follows:

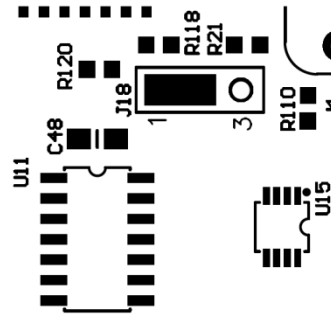

## Required terminal connections

Terminate Cable 17021 low voltage wiring at terminal blocks as follows:

| wire    | terminal description |
|---------|----------------------|
| 1 (RED) | MOTOR1 +             |
| 2 (BLK) | MOTOR1 -             |
| 3 (RED) | +24V                 |
| 4 (BLK) | COM                  |
| 5 (WHT) | BRAKE                |
| 6 (GRN) | SENSOR POWER         |
| 7 (ORG) | SENSOR SIGNAL        |
| 8 (BLU) | UP LIMIT             |

Connect Cable 17031 to controller J23.

## Optional terminal connections

### Edge Sensor

| wire    | terminal description |
|---------|----------------------|
| 9 (BRN) | EDGE SENSOR          |

NOTE: Only install if optional Obstruction Sensor is used. Otherwise install jumper to ground.

### Key test deploy switch

| wire | terminal description |
|------|----------------------|
| 16   | WALL SWITCH +        |
| 17   | WALL SWITCH -        |

NOTE: Wire the wall switch NORMALLY OPEN. Land the two wires from the wall switch at WALL SWITCH+ and WALL SWITCH-

### Door activation switch(es)

| wire | terminal description |
|------|----------------------|
| 11   | DOOR ACTIVATION 1    |
| 12   | DOOR ACTIVATION 2    |
| 13   | GND (SHORTING BLOCK) |

NOTE: Wire the wall switch NORMALLY OPEN. Land the two wires from the wall switch at DOOR ACTIVATION 1 and DOOR ACTIVATION 2.

## Wiring at the Optional Switches

At the keyed wall switch, connect the wires between the normally open contacts. Order of wires does not matter.

At the door activation switch(es), connect the wires between the normally open contacts. Order of wires does not matter.

## Wiring at the Curtain Main Junction Box

### ***Required terminal connections***

---

- In the junction box, connect P1 of cable 17021 to P1 and cable 17031 to P2 coupler.
- On the junction box bulkhead, connect P1 of cable 17020 (motor extension) to "MOTOR".
- Connect motor connector up limit wiring to normally open contacts of up limit switch. Order of wires does not matter.
- Connect P2 of Cable 17020 to motor connector.

## Install Batteries in Control Station *(required final step)*

Perform just prior to initial power on and calibration:

- Connect battery cable positive terminal to the positive terminal of the 1st battery.
- Connect battery cable negative terminal to the negative terminal of the 2nd battery.
- Connect battery jumper cable between the negative terminal of 1st battery and the positive terminal of the 2nd battery